

Simply a question of
better measurement



**SCHMIDT® Flow Sensor
SS 20.715 LED
Instructions for Use**

SCHMIDT® Flow Sensor

SS 20.715 LED

Table of Contents

1	Important Information	3
2	Application Range	4
3	Mounting Instructions	4
4	Electrical Connection.....	7
5	Signalizing	9
6	Startup	11
7	Information concerning Operation	12
8	Service Information.....	13
9	Technical Data.....	14
10	Declarations of Conformity	15

Imprint:

Copyright 2024 **SCHMIDT Technology GmbH**

All rights reserved

Version: 572137.02

Subject to modifications

1 Important Information

These instructions for use contain all required information for a fast commissioning and a safe operation of **SCHMIDT®** flow sensors of the **SS 20.715 LED** type:

- These instructions for use must be read completely and observed carefully, before putting the unit into operation.
- Any claims under the manufacturer's liability for damage resulting from non-observance or non-compliance with these instructions will become void.
- Tampering with the device in any way whatsoever - with the exception of the designated use and the operations described in these instructions for use - will forfeit any warranty and exclude any liability.
- The unit is designed exclusively for the use described below (see chapter 2). In particular, it is not designed for direct or indirect protection of personal and machinery.
- **SCHMIDT Technology** cannot give any warranty as to its suitability for a certain purpose and cannot be held liable for errors contained in these instructions for use or for accidental or sequential damage in connection with the delivery, performance or use of this unit.

Symbols used in this manual

The symbols used in this manual are explained below.



Danger warnings and safety instructions - Read carefully!

Non-observance of these instructions may lead to injury of personal or malfunction of the device.

General note

All dimensions are given in mm.

2 Application Range

The **SCHMIDT® Flow Sensor SS 20.715 LED** (566900) is designed for stationary use in cleanrooms under atmospheric pressure and clean environmental conditions.

The sensor is based on the measuring principle of a thermal anemometer and measures the mass flow of the measuring medium (reference: air) as flow velocity which is output in a linear way as standard velocity¹ (unit: m/s), relative to standard conditions of 1013.25 hPa and 20 °C.

The resulting output signal is independent of pressure and temperature of the medium to be measured.



The sensor is designed for the use inside closed rooms and is not suitable for outdoor use.

3 Mounting Instructions

General information on handling

The **SCHMIDT® Flow Sensor SS 20.715 LED** is a sensitive measuring instrument. Applying mechanical force to the sensor tip should be avoided.



The sensor tip can be damaged irreversibly due to mechanical stress.

Leave the protective cap as long as possible attached during mounting and handle the sensor with care.

Flow characteristics

To avoid false measurement results, appropriate installation conditions must be guaranteed to ensure that the gas flow is supplied to the sensor in a quiet (low in turbulence) state.



Correct measurements requires a laminar² flow with as low turbulence as possible.

¹ Corresponds to the real velocity under standard conditions.

² The term "laminar" means here an airflow low in turbulence (not according to its physical definition saying that the Reynolds number is < 2300).

Mounting sequence

For assembly of the **SCHMIDT® Flow Sensor SS 20.715 LED**, five different assembly versions optimized for use in cleanrooms are available, in order to cover all the different applications (see Table 1).

First, the required holes, depending on the assembly version, must be drilled, and the corresponding mounting bush must be mounted in that hole. Feed connecting cable from cleanroom side through the mounting bush (open cable ends at first) until the cable jack protrudes by about 5 cm out of the receptacle. There must be enough room behind the mounting bush, to allow the cable to be pushed backward when screwing in the sensor. Then connect sensor with connection cable (plug in cable connector and screw on sleeve nut), insert sensor into mounting bush and tighten mounting screw by hand. Now the sensor can still be aligned accurately by hand, if required. Finally, the holding fixture screw must be tightened with a key wrench (wrench size 22) until the sensor is sufficiently secured against twisting.

Prior to commissioning the sensor, remove the protective cap.

Mounting beneath a ceiling

The angled sensor is designed for mounting beneath a ceiling.

After screwing the sensor into the ceiling sleeve, its tip is automatically in the correct position to measure a vertical downdraft flow from the filter outlet. Only the torsional angle of the sensor arm (parallel to ceiling) has to be aligned. Then tighten assembly screw using the key wrench until the sensor is secured against twisting (SW22; hold sensor, if necessary).

Mounting at a wall

The straight sensor is designed for installation at a wall.

Insert sensor into the fixture bushing and thoroughly tighten the assembly screw.

The sensor must be aligned to the flow direction (unidirectional). The correct alignment is in a right angle to an imaginary connection between the two sensor tips (admissible deviation: $\pm 3^\circ$).

For correct flow direction, please observe the direction of the flow arrow on the sensor tube.

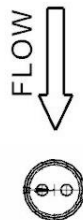

Mounting	Drawing	Assembly
Type 1		<p>Threaded bush M25 with lock nut:</p> <ul style="list-style-type: none"> - For installation in ceilings, walls or frames with a thickness from 1... 22 mm - Opening with Ø of 26 mm required for fixing with lock nut - Or insert a thread M25 x 1.5 into ceiling
Type 2		<p>Threaded bush M25 with threaded adapter M25 x 1.5 for PG:</p> <ul style="list-style-type: none"> - For installation in frames featuring an existing opening with PG21 thread (e.g. sprinkler openings in profiles)
Type 3		<p>Threaded bush M25 with shank nut:</p> <ul style="list-style-type: none"> - For installation in frames with a height of 21 ... 40 mm, especially for ceiling frames made of hollow profiles - Openings with Ø of 26 mm and 28.5 mm are required
Type 4		<p>Welding bush:</p> <ul style="list-style-type: none"> - For welding to ceilings or walls made of stainless steel
Type 5		<p>Flanged bushing:</p> <ul style="list-style-type: none"> - For mounting under the ceiling or at a wall with two screws M6 - Opening in ceiling/wall required with a Ø of 15 mm for cable plus 2 threads M6 - Pressure-tight till 300 mbar

Table 1

4 Electrical Connection

The **SCHMIDT® Flow Sensor SS 20.715 LED** is equipped with a plug-in connector firmly integrated into the enclosure with the following data:

Number of connection pins: 7 (plus shield connection of metallic housing)
 Type: Male
 Locking of connecting cable: M9 spigot nut (on cable)
 Model: Binder, series 712
 Pin numbering:

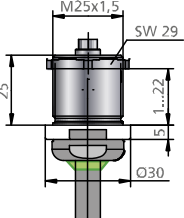
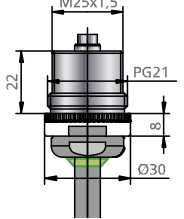
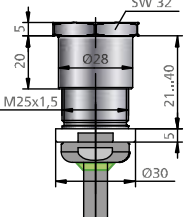
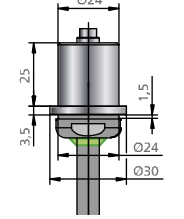
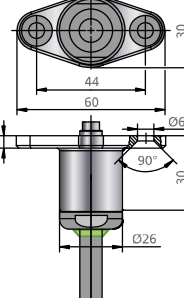
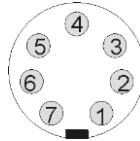

View on connector of sensor

Figure 4-1

The pin assignment of the plug-in connector can be found in Table 2.

Pin	Designation	Function	Wire colour
1	Power	Supply voltage: +U _B	White
2	RS-A	Digital output (Modbus RTU)	Brown
3	RS-B	Digital output (Modbus RTU)	Green
4	A _{out} Temp	Medium temperature signal T _M	Yellow
5	AGND	Ground for analog outputs A _{out}	Grey
6	A _{out} Flow	Flow velocity signal w _N	Pink
7	GND	Supply voltage: Ground	Blue
	Shield	Electromechanical shielding	Shield meshwork

Table 2

All analog signals use AGND³ as electrical reference potential.

The wire colours mentioned in Table 2 are applicable for the use of a cable delivered by **SCHMIDT®** (article numbers: 505911-4, 535279, 535281, 561972, 561973, 565072).

The cable shield is electrically connected to the metallic housing of the sensor, which is coupled to GND indirectly (VDR⁴, in parallel with 100 nF). The shield should be connected to an anti-interference potential, e.g. earth (depending on the shielding concept).



The appropriate protection class III (SELV) respective PELV (according to EN 50178) has to be considered.



During electrical installation, ensure that no supply voltage is applied and inadvertent activation is not possible.

³ AGND is wired to GND within the sensor

⁴ Voltage dependent resistor; breakdown voltage 27 V @ 1 mA

Operating voltage

The **SCHMIDT® Flow Sensor SS 20.715 LED** is protected against a polarity reversal of its operating voltage.

It has a nominal operating voltage range of $U_B = 24 V_{DC} \pm 10 \%$.



Only operate the sensor within the defined operating voltage range (21.6 ... 26.4 V_{DC}).

Undervoltage may result in malfunction; overvoltage may lead to irreversible damage.

The specifications for the operating voltage are valid for the connection at the sensor. Voltage drops generated due to line resistances must be considered by the customer.

Current consumption of the sensor is typically 35/45 mA (voltage/current interface) and at maximum 80 mA (switch-on current).

Analog signal outputs

The analog signal outputs (flow velocity w_N and temperature of the medium T_M) are protected against a short circuit towards both rails.

There are two output versions (selected by ordering):

Current interface:

Signal range ⁵ :	4 ... 20 mA
Type:	High side driver, load resistance against AGND
Maximum load resistance R_L :	300 Ω
Maximum load capacitance C_L :	10 nF
Maximum cable length:	100 m (recommended)
Wiring:	

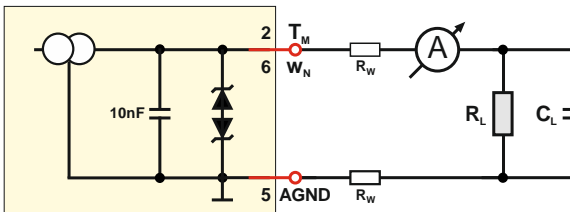

Figure 4-2

Voltage interface:

Signal range:	0 ... 10 V
Type:	High side driver, load resistance against AGND
Minimum load resistance R_L :	10 k Ω
Maximum load capacitance C_L :	10 nF
Maximum short-circuit current:	40 mA
Maximum cable length:	10 m (recommended)
Wiring:	

⁵ Error signaling 2 mA as specified in NAMUR NE 43

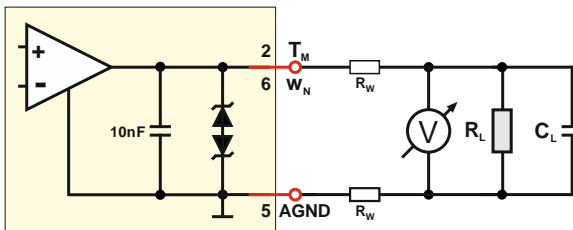

Figure 4-3

Due to the resistance⁶ R_W of the connecting cable, the operating current causes a voltage drop in each wire of the operating voltage, which may adopt interfering values as so-called "mass offset" in the GND wire. It is strongly recommended that AGND is selected as reference potential and/or that wider cable cross-sections are used close to the sensor.



The voltage drop in the GND wire of the connecting cable during operation can substantially falsify the analog signal at the voltage output.

5 Signaling

Analog Outputs

The **SCHMIDT® Flow Sensor SS 20.715 LED** maps the respective measuring quantity linearly to the corresponding analog output.

- Flow velocity w_N :

The measuring range extends from zero flow to the selectable maximum value $w_{N,max}$ (see Table 3).

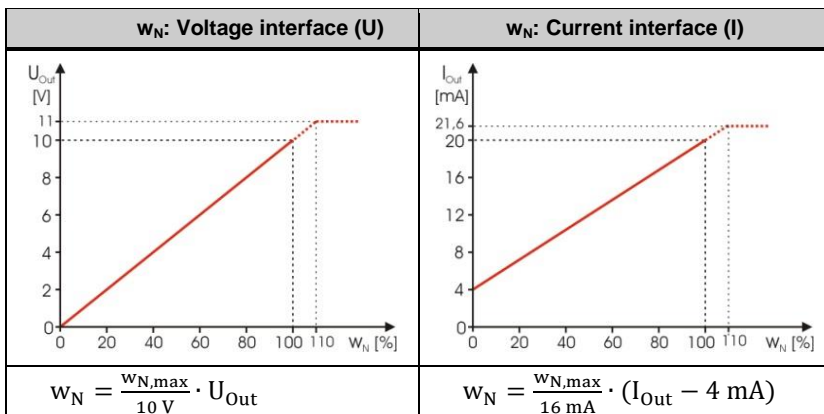

Table 3

⁶ Nominal cable (0.14 mm²): At L = 10 m and $I_{B,max} = 80 \text{ mA}$, up to 133 mV drop out.

- Temperature of the medium T_M :

The measuring range reaches from $-20\text{ }^\circ\text{C}$ up to $+70\text{ }^\circ\text{C}$ (see Table 4).

T_M : Voltage interface (U)	T_M : Current interface (I)
$T_M = \left(\frac{90}{10\text{ V}} \cdot U_{\text{Out}} - 20 \right) ^\circ\text{C}$	$T_M = \left[\frac{90}{16\text{ mA}} \cdot (I_{\text{Out}} - 4\text{ mA}) - 20 \right] ^\circ\text{C}$

Table 4

Note regarding commissioning:

Normally the temperature output provides approx. 5 V resp. 12 mA because the typically prevailing room temperature of approx. $25\text{ }^\circ\text{C}$ corresponds to half of the measuring range.

- Error signaling:
 - The voltage interface is set to 0 V.
 - The current interface outputs 2 mA.
- Overflow (w_N):
 - Flow velocities exceeding the measuring range are furthermore output linearly up to 110 % of the measuring range (11 V or 21.6 mA). For higher values of w_N the output signal remains constant.
- Temperature of medium (T_M) outside of specification range:
 - Operation outside the specified limits may damage the sensor and is displayed as follows (see also graphics in Table 4):
 - Temperature of medium below $-20\text{ }^\circ\text{C}$
 - The analog output for T_M switches to error (0 V or 2 mA).
 - The analog output for w_N switches to error (0 V or 2 mA).
 - Temperature of medium above $+70\text{ }^\circ\text{C}$
 - Measuring values above $T_{M,\text{max}}$ are output in a linear way up to approx. $75\text{ }^\circ\text{C}$ (10.6 V or 20.9 mA).

- Temperature of medium above⁷ +75 °C
The analog output for w_N signals an error (0 V or 2 mA).
The analog output of T_M switches directly to the maximum possible output values of 11 V or 22 mA.

Digital interface

The digital interface of the sensor is compatible to Modbus RTU with the following properties:

- Electrical: RS485 (EIA-485), 2-wire, 3.3 V
- Telegram: 8 data bits, no parity bit, 1 stop bit

For safe operation in a Modbus system, the sensor has to be configured or switched to Modbus mode. For this purpose, as well as for further parameterisation of the sensor, the optional “Programming Kit” (material no.: 564710) can be used.

For more information regarding Modbus mode see the added info flyer.

LED light ring

The **SCHMIDT® Flow Sensor 20.715 LED** indicates its current operating state via a light ring in the holder using coloured light code:

Colour signal	Function/failure
None	Supply voltage: None / reversed / too low
Green pulsing (2 Hz)	Supply voltage: Too high
Red pulsing (2 Hz)	Sensor defective
Red blazing	Only with current interface: Load too big (> 350 Ω)
Green blazing	Sensor operational

Table 5

6 Startup

The **SCHMIDT® Flow Sensor SS 20.715 LED** is ready within 30 s after switch-on.

If the sensor has a temperature different from that of the place of use, this time will increase until the sensor has acclimatised.

⁷ The switching hysteresis for the threshold is approx. 2 K.

7 Information concerning Operation

Ambient condition temperature

The **SCHMIDT® Flow Sensor SS 20.715 LED** monitors the temperature of both medium and electronics. If one of the temperature values leave it's specified operating range, the sensor switches off flow measurement and reports the corresponding error. As soon as proper operational conditions are restored, the sensor resumes normal measuring mode.



Even briefly leaving the specified operating temperature range may result in irreversible damage to the sensor.

Ambient condition medium

The **SCHMIDT® Flow Sensor SS 20.715 LED** is designed for use in clean to slightly contaminated media.



Dirt or other deposits on the head of the sensor cause false measurement results.

Therefore, the sensor must be checked for contamination at regular intervals and cleaned if necessary.

The sensor is made of stainless steel and therefore exhibits a high resistance to chemical media⁸.

Resistance to any chemical must be tested individually due to the different environmental conditions.



Liquid (also condensing) on the sensor head results in serious measurement errors.

After being dried, the sensor will work again correctly provided the condensate has not caused any damage (e.g. by corrosion).

Sterilization

The sensor can be sterilized during operation. In case of condensation on the sensor head, measured value deviations may occur.

Alcohols (drying without leaving residues) and hydrogen peroxide (uncoated version only) are approved and certified disinfectants.

Other disinfectants must be checked by the customer if necessary.

⁸ Even low concentrations of hydrochloric acid may cause pitting corrosion

8 Service Information

Maintenance

Heavy contamination of the sensor head may lead to false measured values. Therefore, the sensor head must be checked for soiling at regular intervals. If contaminations are visible, the sensor can be cleaned as described below.

Cleaning of sensor head

The sensor head can be cleaned by moving it carefully in warm water containing a dishwashing liquid or other allowed cleaning liquid (e.g. isopropanol)⁹. Persistent incrustations or deposits can be previously softened by prolonged immersion and then removed by means of a soft cloth. Avoid applying force to the sensitive sensor tip.



The sensor head is a sensitive measuring system. During manual cleaning, proceed with great care.

Before putting it again into operation, wait until the sensor head is completely dry. The sensor can also be dried using a dry and soft cloth.

Transport / Shipment of the sensor



Before transport or dispatch of the sensor, the delivered protective cap has to be put over the sensor head. Avoid soiling or mechanical stress.

Calibration

If the customer has made no other provisions, we recommend repeating the calibration at a 12-month interval.

To do so, the sensor must be sent in to **SCHMIDT Technology**.

Spare parts or repair

No spare parts are available, since a repair is only possible at **SCHMIDT Technology**. In case of defects, the sensors must be sent in to the supplier for repair.

When the sensor is used in systems important for operation, we recommend you to keep a replacement sensor in stock.

⁹ Other cleaning agents upon request.

Test and material certificates

Every newly produced sensor is accompanied by a certificate of compliance according to EN 10204-2.1, material certificates are not available.

Upon request, we shall prepare, at a charge, a factory calibration certificate, traceable to national standards.

9 Technical Data

Measuring quantities	Standard velocity w_N of air, based on normal conditions of 20 °C and 1,013.25 hPa Temperature of the medium T_M
Measured medium	Air or nitrogen, other gases on request
Measuring range w_N	0 ... 1/2.5/10 m/s
Lower detection limit w_N	0.1 m/s
Measuring accuracy ¹⁰ w_N - Standard - Precision (optional)	$\pm(3\%$ of measured value + 0.05 m/s) $\pm(1\%$ of measured value + 0.04 m/s)
Response time (t_{90}) w_N	15 s
Operating/measuring range T_M	-20 ... +70 °C
Measuring accuracy T_M ($w_N > 1$ m/s)	± 1 K (10 ... 30 °C) ± 2 K (remaining measuring range)
Air/gas humidity	Not condensing ($\leq 95\%$ rH)
Operating pressure	Atmospheric (700 ... 1,300 hPa)
Supply voltage	24 V _{DC} $\pm 10\%$
Current consumption	Typ. < 35/45 mA (max. 80 mA at switch-on)
Analog outputs - Current - Voltage	2 pcs., short-circuit protected (type by ordering) 4 ... 20 mA ($R_L \leq 300 \Omega$; $C_L \leq 10$ nF) 0 ... 10 V ($R_L \geq 10$ k Ω ; $C_L \leq 10$ nF)
Electrical connection	Plug M9 (male), 7-pin (shielded), screwed
Max. line length (rec.)	Voltage interface: 10 m / current interface: 30 m
Protection type ¹¹	IP65
Protection class	III (SELV) or PELV (EN 50178)
Dimensions/material: - Sensor head - Sensor tube: Straight (L) Angled (H x L) - Screw nut	\varnothing max. 15 mm x 90 mm / Stainless steel 1.4404, Epoxy \varnothing 9 mm / Stainless steel 1.4404 300 mm 150 / 270 mm x 300 mm Stainless steel 1.4404
Weight	300 g max. (straight, 300 mm, type 3)

¹⁰ Under reference condition

¹¹ Only with correctly attached connecting cable

10 Declarations of Conformity

SCHMIDT Technology GmbH herewith declares in its sole responsibility, that the product

SCHMIDT® Flow Sensor SS 20.715 LED

Part-No. **566 900**

is in compliance with the appropriate



European guidelines and standards

and



UK statutory requirements and designated standards.

The corresponding declarations of conformity can be download from **SCHMIDT®** homepage:

www.schmidt-sensors.com

www.schmidttechnology.de



SCHMIDT Technology GmbH

Feldbergstraße 1
78112 St. Georgen
Germany

Phone +49 (0)7724 / 89 90

Fax +49 (0)7724 / 89 91 01

E-Mail sensors@schmidttechnology.de

URL www.schmidt-sensors.com
www.schmidttechnology.de