

SCHMIDT® HydroPneumaticPress

Maximum force range from 15 kN to 220 kN



The **SCHMIDT® HydroPneumaticPress** range consists of a modular system suitable for transforming, joining and assembling optimally within the pressing force range 15 – 220 kN.

With the addition of the **SCHMIDT® PressControl 70, 500 A** or **3000** and the optional process monitoring, these presses become EC type-approved, CE-conformed workstations. Therefore these press systems can be used in either single cycle mode or automatic mode.

The application determines selection of the press system. Consideration is given to the flexible design of the assembly location taking into account the ergonomic and safety aspects. These characteristics are achieved by means of a finely adjusted, modular type product range. The efficiency and increased process reliability of these press systems have been proven many thousands of times, in single applications, semi-automated assembly systems and have been integrated into automated production lines.



SCHMIDT® HydroPneumaticPress System Design

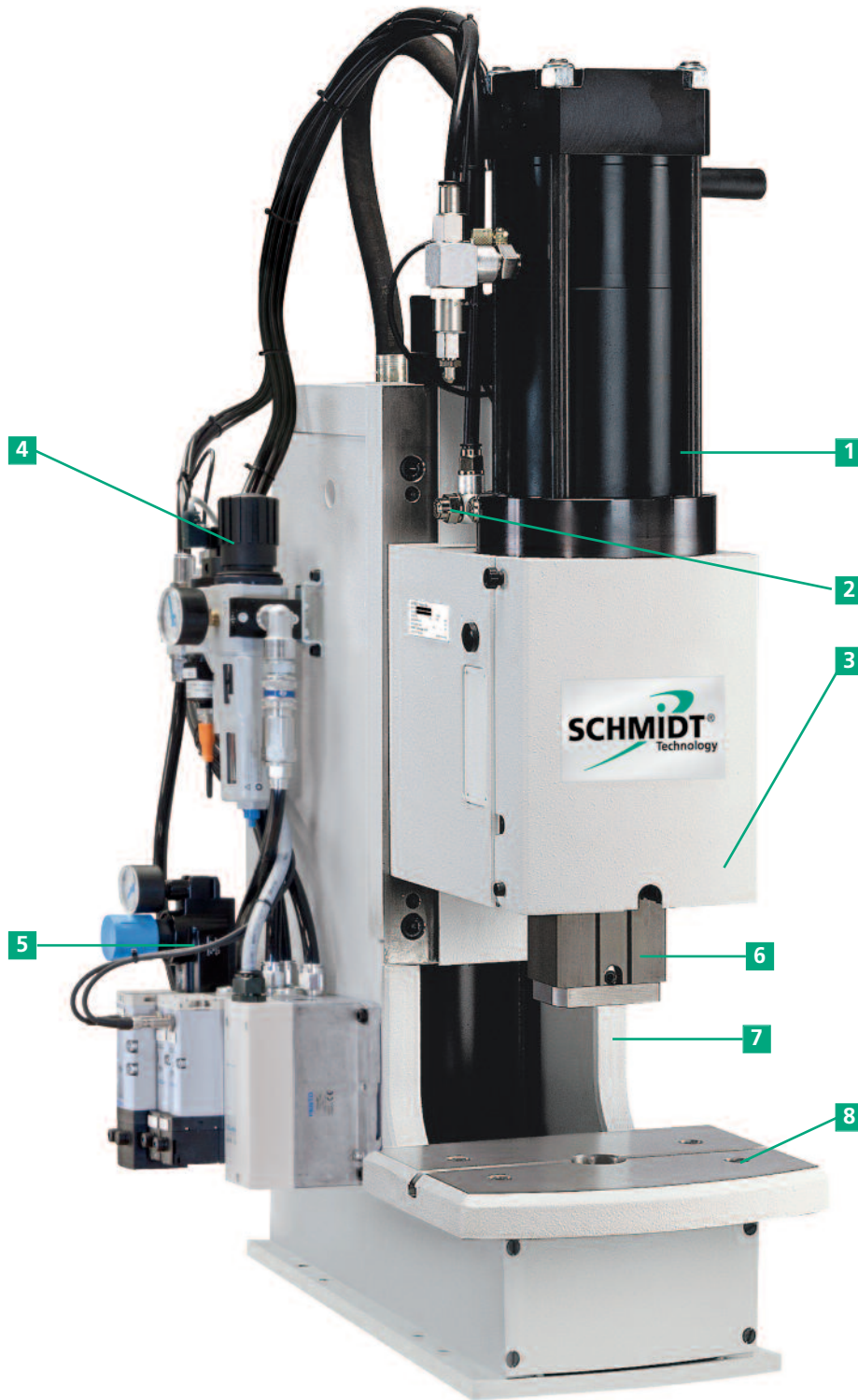

**1) Hydro-pneumatic
Cylinder unit**

**2) Air throttle rapid approach
stroke**

For speed control of the down-
stroke.

3) Press head unit

The working height can be
rapidly & accurately adjusted due
to the height adjustment's ease
of use. Can be used without the
frame as processing station in
automated installations.

4) Pneumatic control package

Two-channel pneumatic package
(as shown) is based on a modu-
lar valve block, designed to oper-
ate with filtered, non-lubricated
air, supply pressure range of
3 – 6 bar.

5) Force output preselector

The press force output can easily
be controlled via a separate pres-
sure regulator and pressure
gauge. The pressure for the
power stroke can be reduced to
1 bar.

6) Square ram

Anti-rotational square ram with
fully adjustable, Teflon lined gibs
for precise travel, precision
machined bore.

7) Frame

With precision machined press
head guide rails (for No. 68 and
368 designed as dovetail guide).

8) Fixture mounting platen

With precision T-slot and bore
for tool location.



Stroke feedback

Ram with key-ways for switch
target pieces for an inductive
position feedback. Optional:
Stroke-dependent activation
of the power stroke by means
of the proximity switch.

SCHMIDT® HydroPneumaticPress

Principle of Operation

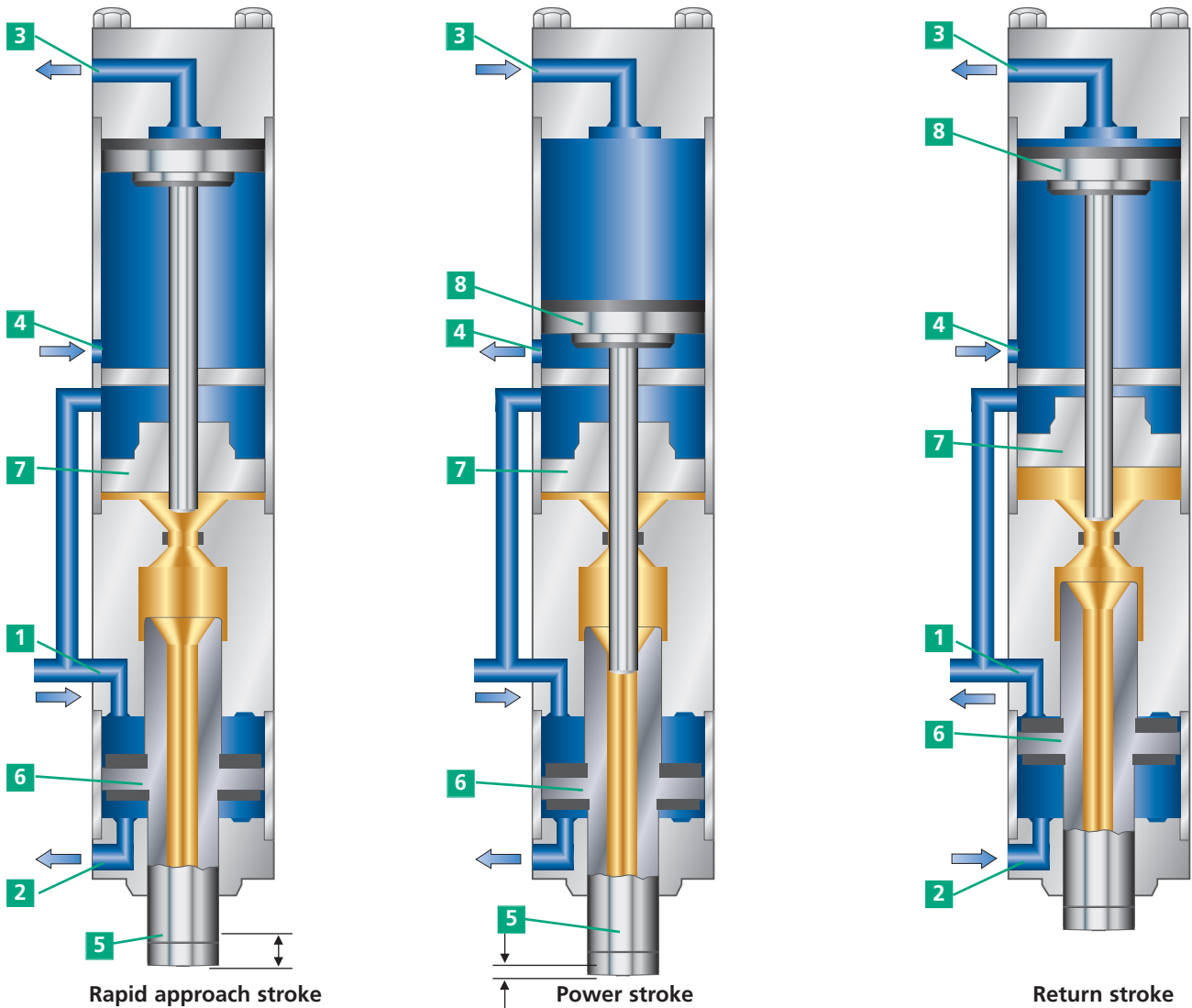

Rapid approach stroke

In rapid approach stroke, the air connections (1) and (4) are pressurized with compressed air. The air connections (2) and (3) are depressurized. The approach stroke piston (6) and the reservoir piston (7) are moving with low force until the ram (5) encounters resistance.

Power stroke

If the ram (5) encounters resistance, a valve switches the compressed air from (4) to connection (3), and the power stroke piston (8) moves downwards. A rod enters the high pressure cylinder, separating the hydraulic oil between reservoir piston (7) and approach stroke piston (6). The ram (5) moves out with boosted force.

Return stroke

For the return stroke, the connections (1) and (3) are depressurized, and the connections (2) and (4) are pressurized. Approach stroke piston (6) and power stroke piston (8) move back simultaneously. After the hydraulic connection between approach (6) and reservoir piston (7) oil flows back into the reservoir, moving the reservoir piston into its home position.

Features:

- Optimally adapted to individual requirements due to its modular design
- High flexibility and economic efficiency due to short changeover times
- Easy and accurate positioning of tools due to the precise alignment between ram bore and the ground fixture mounting platen
- The force output preselector allows reducing the pressure for the power stroke to 1 bar. This reduces the nominal press force to 1/6 of the maximum force.
- The end positions of the ram can be sensed via the inductive proximity switches.
- No mechanical compression spring in the cylinder of the hydro-pneumatic system, providing a long service life
- Low maintenance resulting in high productivity
- Long service life and precision due to maintenance-free guides
- Tool protection due to smooth switchover from rapid approach stroke to power stroke
- Additional safety when using heavy tools due to the optional ram drift lock device for retention of ram in home position.
- Low noise level (< 75 dBA)

SCHMIDT® HydroPneumaticPress

C-Frame Design



61 / 62



65

Features:

- The C-Frame design offers full accessibility when manually inserting and removing parts.
- Easy adaptation to different tool and part heights because of simplistic height adjustment with angular gear.
- Anti-rotational square ram with fully adjustable, Teflon lined gibs for precise travel. No die set required.
- High precision due to long precise guides of the square ram.

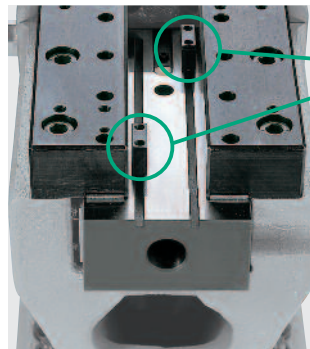

Adjustable switch target pieces for position detection via an inductive position sensor.

Rapid approach stroke

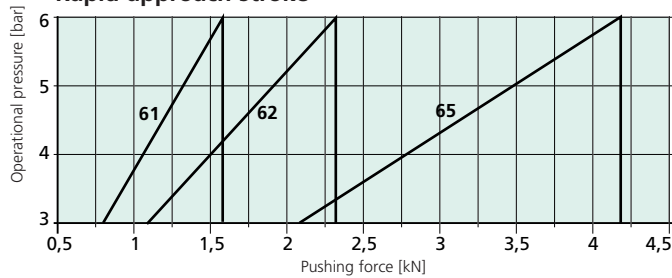

Square ram

with bilaterally adjustable, play-free gibs, precision machined bore with set screw for mounting of tooling. Some models feature additional provisions for tooling adaption.

Return stroke

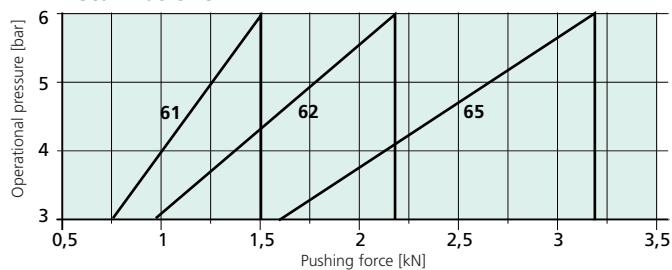

Power stroke

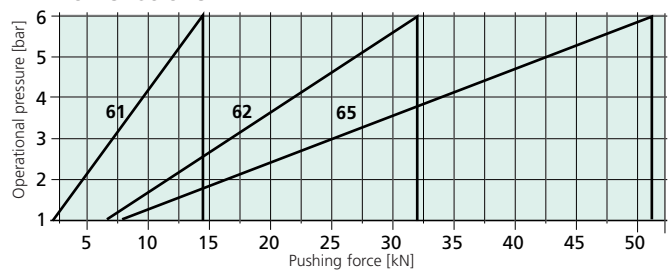

From 15 kN to 52 kN in power stroke

Press type		61	62	65
Total stroke – power stroke ¹⁾	mm	50-6, 100-12	50-6, 100-12	50-6, 100-12
Nominal force at 6 bar	kN	15	30	52
Throat depth	mm	131	131	160
Throat depth frame \bigcirc	mm	151	151	185
Fixture mounting plate suitable for throat depth frame		\bigcirc	\bigcirc	\bigcirc
Ram bore (with bushing)	\varnothing mm	20H7	20H7	20H7
External ram dimensions $G \times H$	mm	36 x 63	36 x 63	46 x 86
Front side ram drill pattern		\bigcirc	\bigcirc	\bigcirc
Working height	F			
Frame No. 34	mm	100 – 250	100 – 250	
Frame No. 301 \bigcirc	mm	160 – 400	160 – 400	
Frame No. 301-500 \bigcirc	mm	310 – 500	310 – 500	
Frame No. 35	mm			100 – 270
Frame No. 35-500 \bigcirc	mm			150 – 500
Frame No. 35-600 \bigcirc	mm			250 – 600
Weight (standard)	approx. kg	95	110	160

Frame overview						
Frame type	Press type	Frame height M	Table size W x D	Table bore	Table height K	Mounting surface W x L
No. 34	61, 62	630	200 x 160	\varnothing 25H7	111	200 x 370
No. 301	61, 62	830	250 x 200	40H7	145	250 x 460
No. 301-500	61, 62	990	250 x 200	40H7	145	250 x 480
Special fixture mounting platen with 3 longitudinal slots \bigcirc			300 x 220	40H7		
			400 x 230	40H7		
No. 35	65	700	300 x 220	40H7	141	300 x 480
No. 35-500	65	990	300 x 220	40H7	166	300 x 560
No. 35-600	65	1110	300 x 220	40H7	166	300 x 585
Special fixture mounting platen with 3 longitudinal slots \bigcirc			355 x 225	40H7		
			400 x 280	40H7		

Options

\bigcirc = Additional charge applies

¹⁾ = Special models total stroke / power stroke on request

Please consult our Sales Department or Representative.

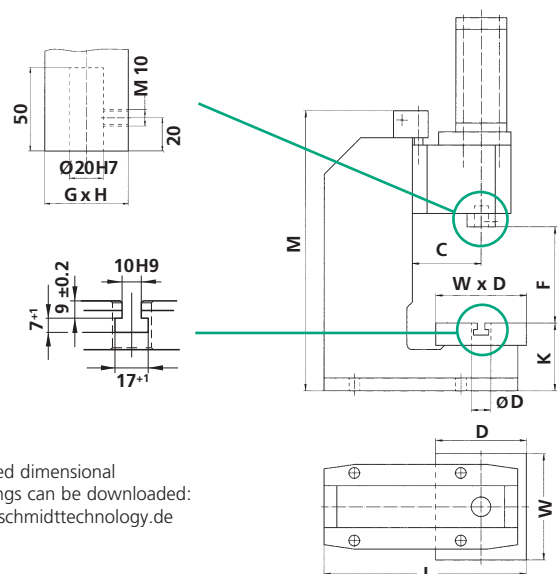

Detailed dimensional drawings can be downloaded:
www.schmidtechnology.de

SCHMIDT® HydroPneumaticPress

Welded C-Frame Design



Features:

- The welded press frame offers highest stability.
- Space-saving and compact due to separate working cylinder for press No. 68

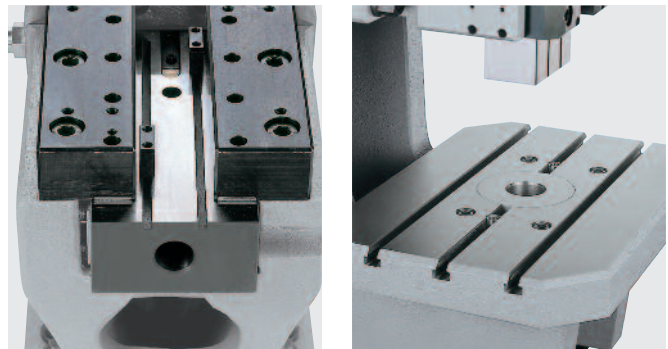

Rapid approach stroke

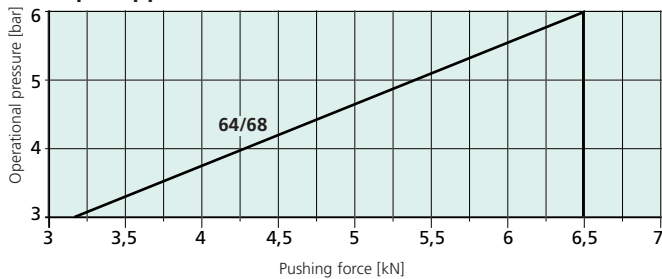

Square ram

with bilaterally adjustable, play-free gibs, precision ground bore with set screw for mounting of tooling. Some models feature additional provisions for tooling adaption.

Fixture mounting plate

(for press No. 64) with 3 T-slots and precision-machined bore for tool location.

Return stroke

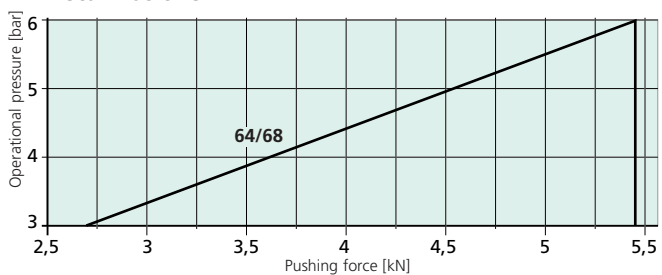

Power stroke

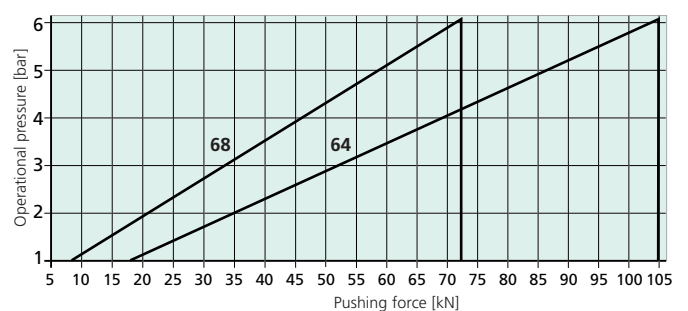

From 72 kN to 100 kN in power stroke

Press type		64	68
Total stroke – power stroke ¹⁾	mm	50-6, 100-12	50-6, 100-12
Nominal force at 6 bar	kN	100	72
Throat depth	C mm	160	160
Ram bore (with bushing)	D mm	25H7	20H7
External ram dimensions	G x H mm	60 x 90	60 x 90
Working height	F		
Frame No. 64	mm	180 – 350	
Frame No. 64-600 ○	mm	430 – 600	
Frame No. 68 ²⁾	mm		130 – 300
Frame No. 68/5 ²⁾ ○	mm		190 – 460
Weight (standard)	approx. kg	420	350

Frame overview						
Frame type	Press type	Frame height	Table size	Table bore	Table height	Mounting surface
		M	W x D	Ø mm	K	W x L
		mm	mm		mm	mm
No. 64	64	940	400 x 290	40H7	185	
No. 64-600	64	1200	400 x 290	40H7	185	400 x 290
No. 68 ²⁾	68	810	300 x 230	40H7	147	300 x 550
No. 68/5 ²⁾	68	990	300 x 230	40H7	147	300 x 620
Special fixture mounting platen with 3 longitudinal slots ○			400 x 280 500 x 280	40H7 40H7		

Options

○ = Additional charge applies

¹⁾ = Special models total stroke / power stroke on request

²⁾ = Frame 68/5 required for 30 mm power stroke

Please consult our Sales Department or Representative.

Bottom view of the press head

Mounting drill pattern flange / ram

64

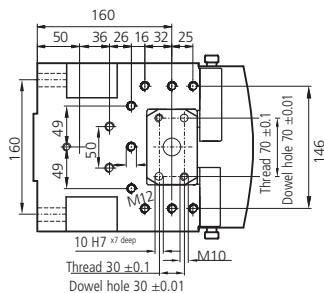

68

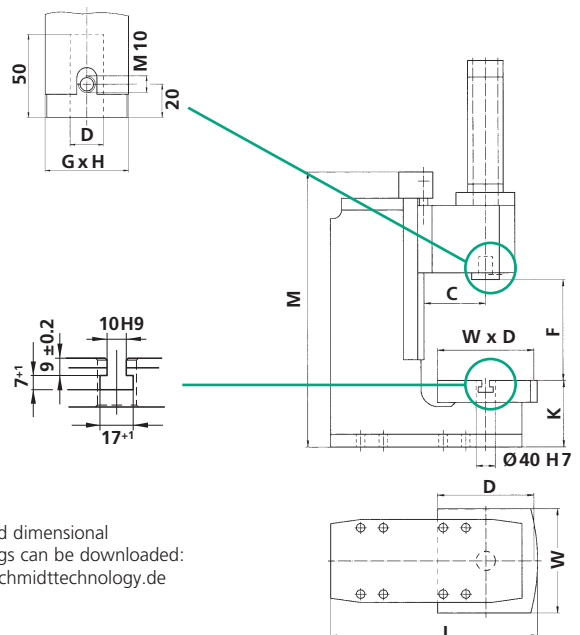
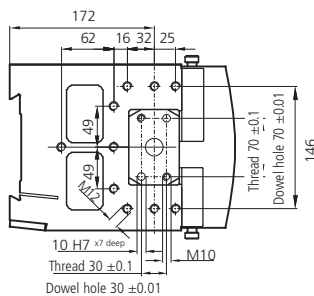

Detailed dimensional drawings can be downloaded:
www.schmidttechnology.de

SCHMIDT® HydroPneumaticPress

C-Frame Design with force/stroke monitoring



SCHMIDT® HydroPneumaticPresses with force/stroke monitoring are offered as complete system with control unit **SCHMIDT® PressControl 3000**. These systems are characterized by sensors and signal amplification integrated in the press head. These signals are evaluated in real time.

Features:

- Direct forces are measured due to the force sensor integrated in the ram. Insensitive against side forces.
- Signal readings are not affected by outside interference.
- A measuring data amplification integrated in the press head provides short transmission paths of unamplified signals.
- Precision guide rails for precise working. Bilaterally adjustable, play-free gibs, precision machined bore for tool location. No die-set required.

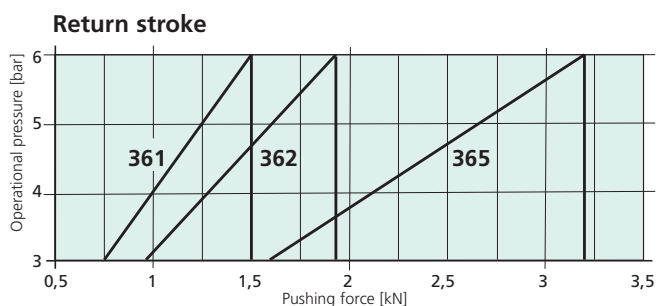
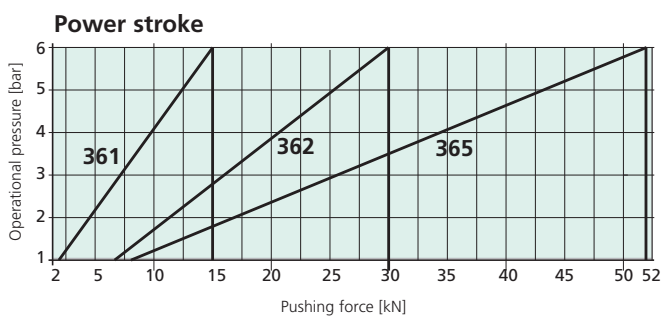
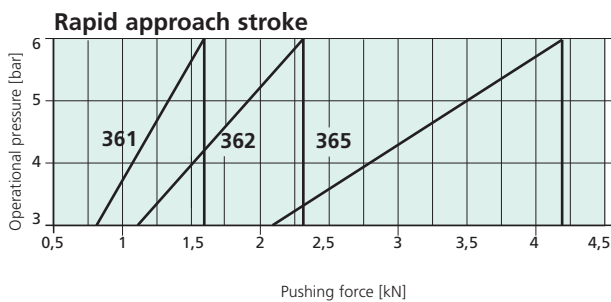

From 15 kN to 52 kN in power stroke

Press type	361	362	365
Total stroke – power stroke ¹⁾	50-6, 100-12	50-6, 100-12	50-6, 100-12
Nominal force at 6 bar	15	30	52
Resolution, process data acquisition			
– stroke	5	5	5
– force	10	25	50
Throat depth C	131	160	160
Throat depth frame ○	151		
Fixture mounting plate suitable for throat depth frame ○			
Ram bore (with bushing)	20H7	20H7	20H7
External ram dimensions G x H	70 x 50	90 x 60	90 x 60
Working height F			
Frame No. 301	160 – 400		
Frame 301-500 ○	310 – 500		
Frame No. 329		130 – 300	130 – 300
Frame No. 329-460 ○		190 – 460	190 – 460
Weight (standard)	approx. 170	320	330

Frame type	Press type	Frame height	Table size	Table bore	Table height	Mounting surface
		M	W x D	Ø mm	K	W x L
No. 301	361	830	250 x 200	40H7	145	250 x 460
No. 301-500	361	990	250 x 200	40H7	145	250 x 480
Special fixture mounting platen with 3 longitudinal slots ○			300 x 220	40H7		
			400 x 230	40H7		
No. 329	362, 365	810	300 x 230	40H7	147	300 x 550
No. 329-460	362, 365	990	300 x 230	40H7	147	300 x 620
Special fixture mounting platen with 3 longitudinal slots ○			400 x 280	40H7		
			500 x 280	40H7		

Options

- = Additional charge applies
- ¹⁾ = Special models total stroke / power stroke on request

Please consult our Sales Department or Representative.

Bottom view of the press head

Mounting drill pattern flange / ram

361

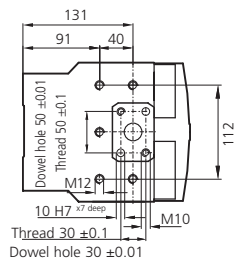

362 / 365

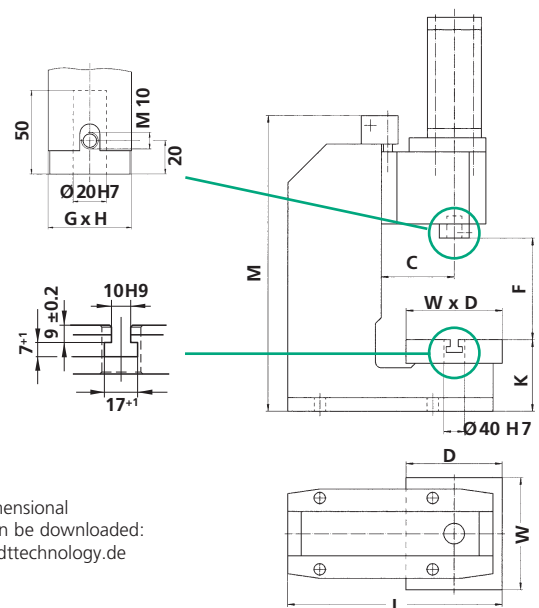
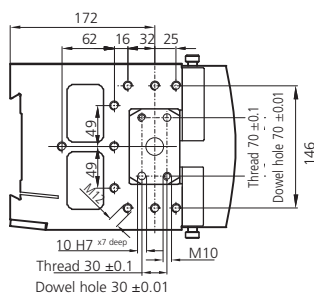

Detailed dimensional drawings can be downloaded:
www.schmidttechnology.de

SCHMIDT® HydroPneumaticPress

In C-Frame design with force/stroke monitoring



SCHMIDT®
HydroPneumaticPresses with force/stroke monitoring are offered as complete system with control unit **SCHMIDT® PressControl 3000**. These systems are characterized by sensors and signal amplification integrated in the press head. These signals are evaluated in real time.

Features:

- Direct forces are measured due to the force sensor integrated in the ram. Insensitive against side forces.
- Signal readings are not affected by outside interference.
- A measuring data amplification integrated in the press head provides short transmission paths of unamplified signals.
- Precision bilaterally adjustable, play-free gibs, precision ground bore for tool location. No die-set required.

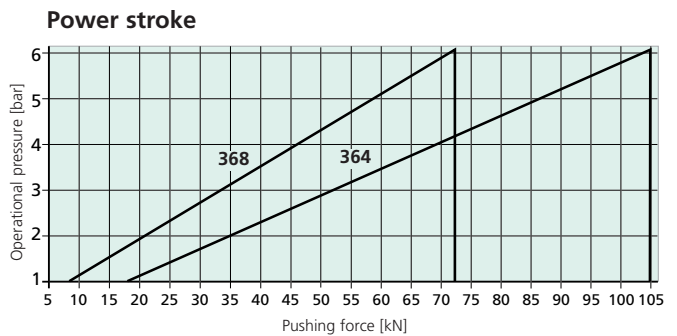
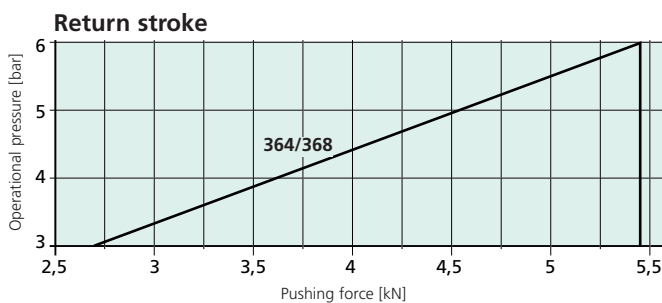
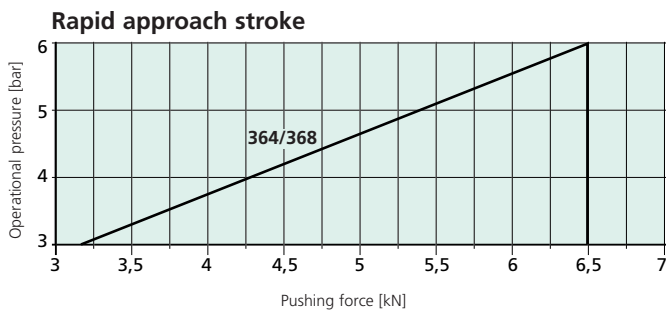

From 72 kN to 100 kN in power stroke

Press type		364	368
Total stroke – power stroke ¹⁾	mm	50-6, 100-12	50-6, 100-12
Nominal force at 6 bar	kN	100	72
Resolution, process data acquisition			
– stroke	µm/inc	5	5
– force	N/inc	62.5	50
Throat depth	C mm	160	160
Ram bore (with bushing)	D Ø mm	25H7	20H7
External ram dimensions	G x H mm	90 x 60	90 x 60
Working height	F		
Frame No. 64	mm	180 – 350	
Frame No. 64-600 ○	mm	430 – 600	
Frame No. 68 ²⁾	mm		130 – 300
Frame No. 68/5 ²⁾ ○	mm		190 – 460
Weight (standard)	approx. kg	420	350

Frame type	Press type	Frame height M	Table size W x D	Table bore Ø mm	Table height K	Mounting surface W x L
No. 64	364	940	400 x 290	40H7	185	400 x 625
No. 64-600	364	1200	400 x 290	40H7	185	400 x 685
No. 68 ²⁾	368	810	300 x 230	40H7	147	300 x 550
No. 68/5 ²⁾	368	990	300 x 230	40H7	147	300 x 620
Special fixture mounting platen with 3 longitudinal slots ○			400 x 280 500 x 280	40H7 40H7		

Options

○ = Additional charge applies

¹⁾ = Special models total stroke / power stroke on request

²⁾ = Frame 68/5 required for 30 mm power stroke

Please consult our Sales Department or Representative.

Bottom view of the press head

Mounting drill pattern flange / ram

364

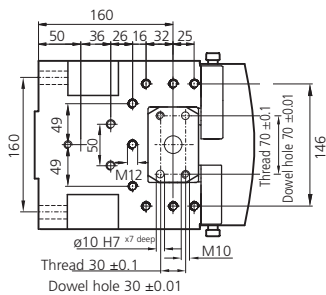

368

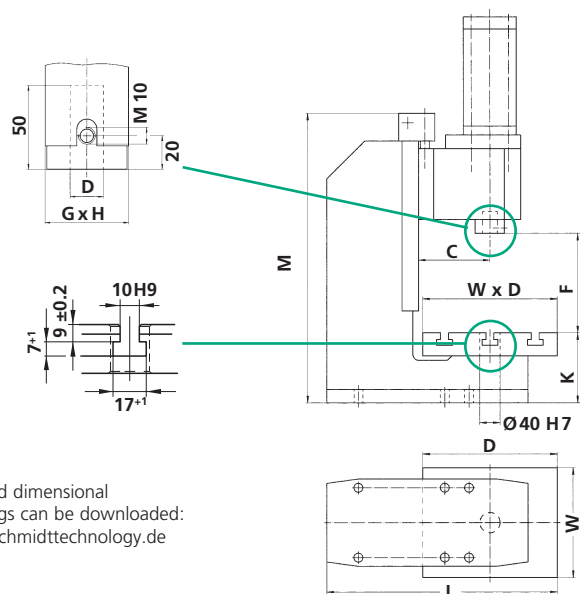
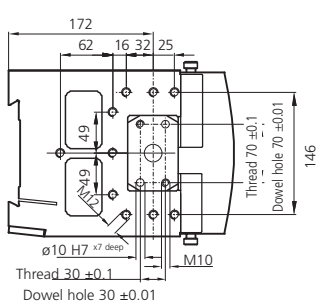

Detailed dimensional drawings can be downloaded:
www.schmidttechnology.de

SCHMIDT® HydroPneumaticPress

H-Frame design with and without force/stroke monitoring

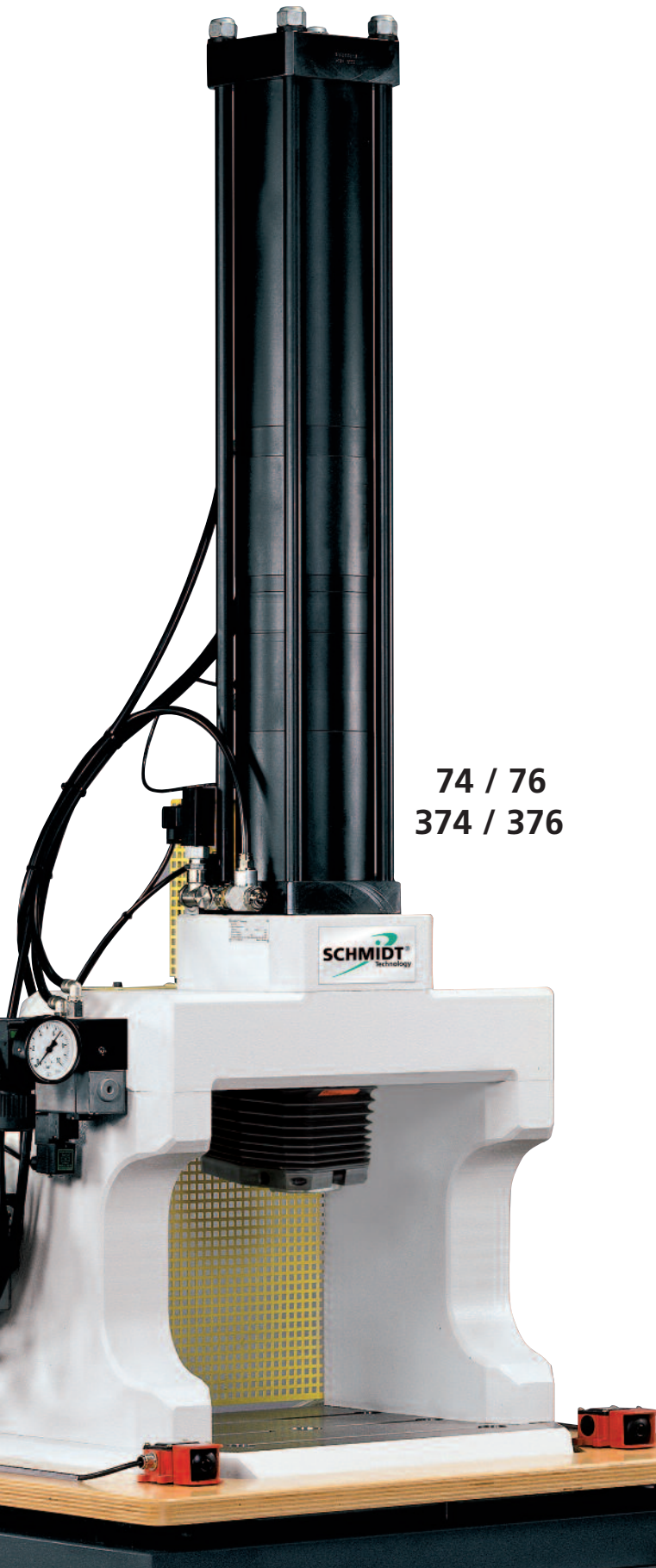

74 / 76
374 / 376



Round ram locked against rotation with TDC switch (74/76) or position measuring system (374/376) on the rotational guide rod.

Features:

- Stable frame with low bending for the absorption of high forces.
- Flexible tool location in the fixture mounting plate due to replaceable centering bushing with precision bore.
- The large working area offers sufficient space for large tools.
- The force is determined via a pressure transducer with force/stroke monitored presses.

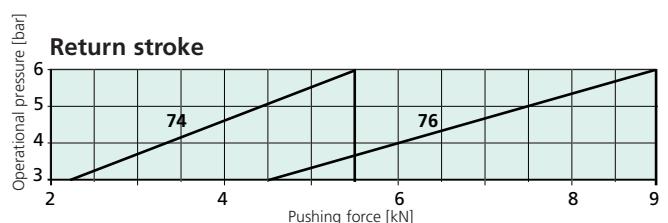
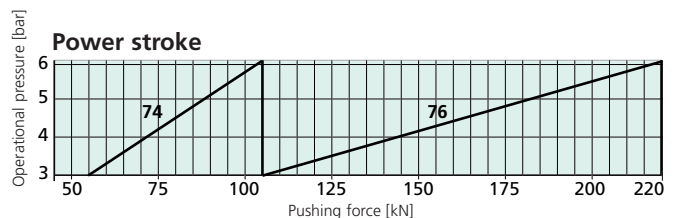
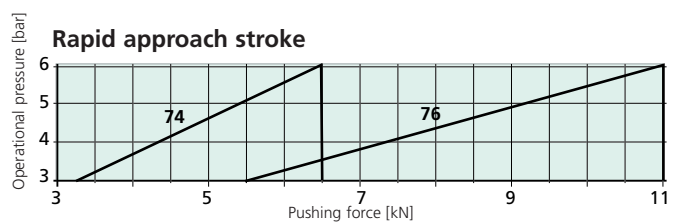
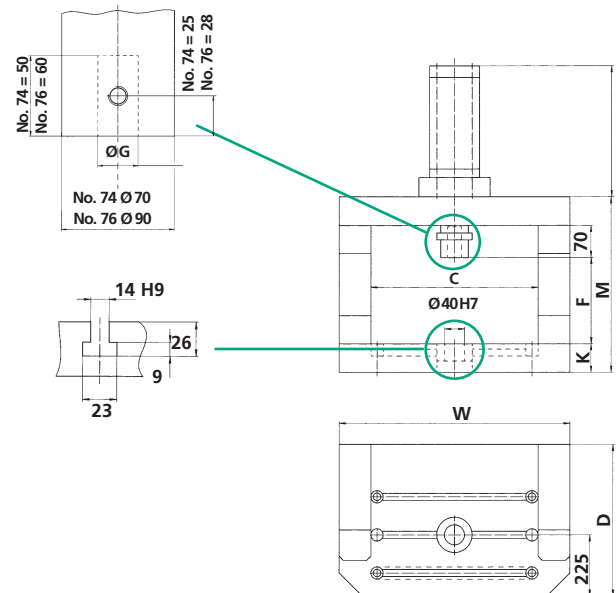

From 100 kN to 220 kN in power stroke

Press type		74	76
Total stroke – power stroke ¹⁾	mm	100-12	100-12
Nominal force at 6 bar	kN	100	220
Ram bore (with bushing)	Ø mm	25H7	32H7
External ram dimensions	Ø mm	70	90
Working height	F mm	350	350
Table height	K mm	95	95
Frame height	M mm	640	640
Table size	W x D mm	700 x 550	700 x 550
Table bore	Ø mm	40H7	40H7
Clearance	C mm	420	420
Clearance ○	mm	520	520
Weight (standard)	approx. kg	730	760

Press type		374	376
Total stroke – power stroke ¹⁾	mm	100-12	100-12
Nominal force at 6 bar	kN	100	220
Resolution, process data acquisition			
– stroke	µm	5	5
– force	N / inc	50	100
Ram bore	Ø mm	25H7	32H7
External ram dimensions	Ø mm	70	90
Working height	F mm	350	350
Table height	K mm	95	95
Frame height	M mm	640	640
Table size	W x D mm	700 x 550	700 x 550
Table bore	Ø mm	40H7	40H7
Clearance	C mm	420	420
Clearance ○	mm	520	520
Weight (standard)	approx. kg	730	760

Options

○ = Additional charge applies

¹⁾ = Special models total stroke / power stroke on request

Please consult our Sales Department or Representative.

Detailed dimensional drawings can be downloaded:
www.schmidttechnology.de

Accessories



High-pressure switch

After switching from rapid approach stroke to power stroke, the oil pressure rises in the hydraulic chamber of the cylinder. The high-pressure switch can be adjusted to reach a determined press force through the output generated by the oil pressure in the press.

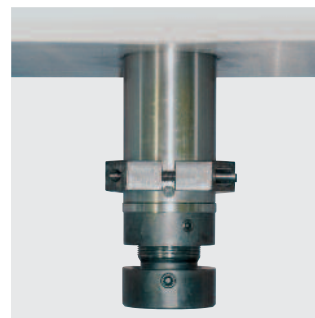

Adjustment bushing for SCHMIDT[®] HydroPneumaticPress No. 74 and 76 H-Frame design presses

For a simplistic adjustment of the working height with a setting range of 100 mm. This greatly reduces the need for spacers to accommodate different working heights during setup changes.



Oil pump

For a air-free refilling of the SCHMIDT[®] HydroPneumaticPress with hydraulic oil.